

Lifting bottom centrifuge

Chips centrifuge DS32 to DS100



>> Advantages

- > Continuous operation
- > Long service life
- > Highly wear-resistant execution
- > Vibration-proof set-up
- > Best possible degree of dryness
- > Fully automatic and continuous operation
- > Compact design
- > Very low maintenance costs
- > Particularly easy to maintain
- > Self-cleaning

>> Functional principle

In the fully automatic operation the wet chips or the sludge fall over the infeed hopper into the drum of the lifting bottom centrifuge. At this point the chips meet the rotating lifting bottom and are pressed against the drum wall under high centrifugal forces. The hydraulically activated lifting bottom moves the chips and/or the sludge upwards to the slot sieve where the liquids are separated from the chips. After a few lifting cycles the dried chips are carried over the edge of drum and quit the centrifuge into the container or discharge conveyor. The centrifuged liquid can be returned to the production or pumped back for further treatment.

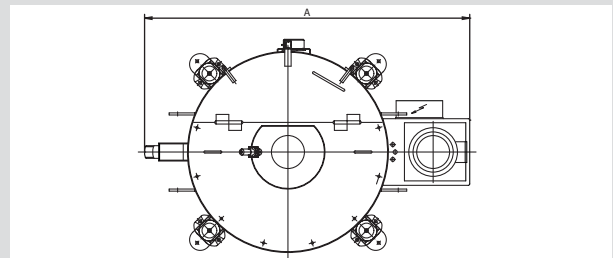
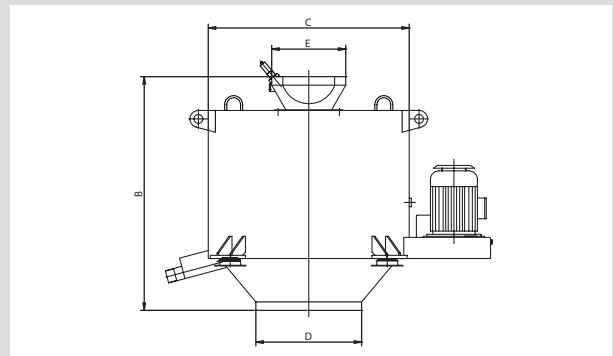

Type	Throughput* [kg/h]				Grinding sludge	Dimensions [mm]					Capacity [kW]	Weight [kg]
	Steel / Stainless steel	Brass	Grey cast iron	Aluminium		A	B	C Ø	D Ø	E Ø		
DS32	375	280	560	125	250	1.330	1.030	850	400	300	2,2	450
DS40	750	560	1.125	250	500	1.540	1.100	950	500	350	2,2	750
DS50	1.500	1.120	2.250	500	1.000	1.740	1.160	1.060	550	400	3,5	950
DS60	3.000	2.240	4.500	1.000	2.000	2.020	1.320	1.230	600	450	2,2	1.750
DS80	6.000	4.480	9.000	2.000	4.000	2.280	1.520	1.500	700	600	7,5	2.600
DS100	10.000	5.960	15.000	3.000	8.000	2.950	1.800	1.960	1.000	700	15	5.600

* Throughput depending on kind of material and coolant

